

# EU-TYPE EXAMINATION CERTIFICATE

Issued by Liftinstituut B.V.  
 identification number Notified Body 0400,  
 commissioned by Decree no. 2016-0000038870

Certificate no. : NL18-400-1002-295-01      Revision no.: -

Description of the product : Brake as Ascending Car Overspeed protection (ACOP) to prevent uncontrolled upward movement of the car and as Unintended Car Movement Protection (UCMP) means

Trademark, type : Shenyang Bluelight Drive Technology Co.,Ltd., BLB

Name and address of the manufacturer : Shenyang Bluelight Drive Technology Co.,Ltd.  
 No.37 Shiji Road, Hunnan New District, Shenyang City, 110179 P.R. China.

Name and address of the certificate holder : Shenyang Bluelight Drive Technology Co.,Ltd.  
 No.37 Shiji Road, Hunnan New District, Shenyang City, 110179 P.R. China.

Certificate issued on the following requirements : Lifts Directive 2014/33/EU

Certificate based on the following standard : Parts of: EN 81-20:2014, EN 81-50:2014, EN 81-1:1998+A3:2009

Test laboratory : SISE, No.1032, Honggang Road, Luohu District, Shenzhen, 518029, P.R. China

Date and number of the laboratory report : 2017AF0144, 28-02-2017  
 2017AF4186, 01-12-2017

Date of EU-type examination : May – August 2018

Additional document with this certificate : Report belonging to the EU-type examination certificate no.: NL18-400-1002-295-01

Additional remarks : Min Nom Torque                    2 x 2044 Nm  
 Max air gap                                0,30-0,55 mm  
 Max response time  $t_{10}$             45 ms                    110VDC  
 Max response time  $t_{90}$             300 ms                   110VDC  
 Max tripping speed                    366 rpm / 3,83 m/s  
 Furthermore, see chapter 2 and 5 of the report belonging to this EU- type examination certificate.

Conclusion : The safety component meets the requirements of the Lifts Directive 2014/33/EU taking into account any additional remarks mentioned above.



Amsterdam

Date : 02-08-2018  
 Valid until : 02-08-2023

ing. P.J. Peeters  
 Manager

Certification decision by

## Report EU-type examination

Report belonging to EU-type examination certificate no.	: NL18-400-1002-295-01
Date of issue of original certificate	: August 02, 2018
Concerns	: Safety component
No. and date of revision	: -
Requirements	: Lifts Directive 2014/33/EU Standards: EN81-20:2014, EN81-50:2014 EN 81-1:1998+A3:2009
Project no.	: P180238

### 1. General specifications

Name and address manufacturer	: Shenyang Bluelight Drive Technology Co.,Ltd. No.37 Shiji Road, Hunnan New District, Shenyang City, 110179 P.R. China.
Description of safety component	: Brake as Ascending Car Overspeed protection (ACOP) to prevent uncontrolled upward movement of the car and as Unintended Car Movement Protection (UCMP) means
Type	: BLB
Laboratory	: SISE, No.1032, Honggang Road, Luohu District, Shenzhen, 518029, P.R. China
Data of examination	: May - August 2018
Examination performed by	: W.Visser

### 2. Description safety component

The Shenyang Bluelight Drive BLB, 2x2044 Nm is a brake that consist of two independent electro-mechanical block brakes, which fulfils the requirements for lift brakes according to clause 5.9.2.2.2 of EN81-20:2014 and is mounted to a Shenyang Bluelight Drive WYT-T gearless machine.

The brake has two sets of two coils in the housing allowing separate electrical opening of the two brake halves.

The brake parts act on the traction sheave (e.g. on the brake drum that is bolted to the traction sheave directly by bolts), connected to the drive shaft by key and keyway. In that case the connections are proven to have built in redundancy. The brakes are

also used as holding brakes during normal operation of the lift. The brake material is glued to the brake shoes and the shoes are bolted to the base.

### ACOP

The Ascending Car Overspeed Protection shall be actuated by a governor overspeed contact or an equivalent EU-type tested device which was no part of this investigation.

### UCMP

The brake can be used as braking element for Unintended Car Movement Protections according Art. 5.6.7 of EN 81-20:2014.

The brake torque for each type is pre-determined in the factory by application of a fixed amount of guided compression springs. The torque is indicated on a label attached to the brake. This setting is sufficient until the air gap between magnetic core and brake lining exceeds 0,65 mm. Each brake part is separately provided with a monitoring contact. The controller of the lift in which these brakes are used, must check the signals from each brake contact according to Art. 5.6.7.9 of EN 81-20:2014. If a failure is detected, the lift must be put out of service permanently.

The brake delay times  $t_{10}$  and/or  $t_{90}$  as indicated in this report shall be used to check by means of calculation that the stopping distance of the car fulfils the requirements.  $t_{10}$  means the time from activation until the moment that 10% of the nominal brake torque has been reached ( $T_{10}$ ) and  $t_{90}$  means the time from activation until the moment that 90% of the nominal brake torque ( $T_{90}$ ) has been reached.

A value of brake delay time between  $t_{10}$  and  $t_{90}$  can be interpolated if needed.

The defined and calculated nominal torque per brake is the minimum guaranteed torque under the conditions which the manufacturer prescribes during the lifetime of the brake.

### Brake Coil Connections

A brake connection box is mounted on top of the machine. It has a 110VDC input from a rectifier inside the lift control panel. Main contactors are on the DC side.

### BRAKE DATA

Manufacturer	Shenyang Bluelight Drive Technology
Type	BLB
Number of friction surfaces	2
Number of brake springs	2 x 20
Brake drum diameter [mm]	610
Air gap between brake drum and brake shoe [mm]	0,30-0,55
Min-Max allowed tripping speed	55 - 366 rpm / 0,58 - 3,83 m/s
Nominal torque	2 x 2044 Nm
Exciting / holding voltage [VDC]	110 / 110
t-10 (maximum value measured)	45 msec
t-90 (maximum value measured)	300 msec

**TRACTION MACHINE APPLICATION DATA**

Shenyang Bluelight Drive Technology	WYT-T
Q=Nominal capacity range [kg]	450 - 2500
P=Car mass range [kg]	610 - 5375
System mass range [kg]	1400 - 12000
Max. rated motor torque [Nm]	1635
Roping factor	2:1
Traction sheave diameter [mm]	400
Max. allowed rpm traction sheave /speed lift	286 rpm / 3,00 m/s
Max. allowed tripping rpm/speed ACOP	366 rpm / 3,83 m/s
Bolted connection traction sheave -brake disc	8 x M12

### 3. Examinations and tests

The examination covered a check whether compliance with the Lifts Directive 2014/33/EU is met, based on the harmonized product standards EN81-20:2014 and EN81-50:2014. The examination included:

- Examination of the technical file (See annex 2):
- Check of performed calculations according to EN81-20 and EN81-50.
- Examination of the representative model in order to establish conformity with the technical file.
- Inspections and tests to check compliance with the essential requirements of the EN 81-50 Art. 5.7 and 5.8 at Shenzhen Institute of Special Equipment, Inspection and Research, Guangdong station Of Elevator Quality Supervision and Test (SISE). All results are described in the following SISE Test Reports:

<b>ACOP</b>	2017AF0144
<b>UCMP</b>	2017AF4186

Liftinstituut verified and accepts the tests and the results by this ISO 17025 accredited laboratory.

- Tests to verify the required monitoring according to Art. 5.6.7.3 of EN 81-20.
- The machine was placed on a test stand with a coupling to an intermediate shaft with a torque meter. (See annex 1c). On the other side of this intermediate shaft is an electric driving motor with overrated power to the shaft. The torque is stored as a function of time with a digital oscilloscope.
- The torque meter was calibrated in advance by an ISO 17025 accredited laboratory.
- The test stand is provided with additional flywheels that can be coupled to the setup but the inertia of the test stand on its own was found to be more than the maximum inertia for the application range defined for the ACOP for these traction machines.
- The electromotor is run with high torque at the highest speed anticipated before deceleration occurs (tripping rpm's of the brake). These maximum

tripping rpm's are calculated based on the maximum tripping speed of the applied overspeed governor, which overspeed tripping contact activates the brake as ACOP. After constant speed is reached, the brake holding voltage is cut and the brake set is applied until the machine has come to a full stop, while the electromotor continues giving the unbalance torque calculated from the maximum allowed unbalance for the applicable machine. This test is done 10 times in clockwise direction and 10 times in counter clock wise direction with the complete brake.

- The results of the torque measurement has been recorded and studied. From these results the dynamic torque and the reaction times  $t_{10}$  and  $t_{90}$  have been established. Also the functioning of the monitoring contacts has been tested. Immediately after each test the temperature of the brake housing and brake discs was checked.
- The test has been performed with brake contactors on the DC side. DC values for each brake are mentioned in chapter 2 of this report. The power to the brake shall always be interrupted on DC side to ensure the specified delay times.

## 4. Results

### 4.1. Calculations

Calculations of the maximum torque of the machine/system and brake torque were checked and found in order.

Brake clutch surface pressure calculations and brake spring calculations were checked and found in order.

The strength calculations of connecting bolts between the brake disc and traction sheave were checked and found in order.

### 4.2. Measurements

The tests on the test bench showed that the measured torque of the brake was significantly higher than the calculated torque by the manufacturer and that the brake is capable of absorbing sufficient kinetic energy.

After the final examination the product and the technical file were found in accordance with the requirements.

## 5. Conditions

On the EU-type examination certificate the following conditions apply:

- The application of this certificate is limited to the brake mentioned in chapter 2 used as brake set for lift applications. Each brake set consists of two independent electro-mechanical block brakes and fulfil the requirements for lift brakes according article 5.9.2.2.2 of EN 81-20:2014.

- Lifts to be built according EN 81-20 shall fulfil Art. 5.9.2.2.2.7 allowing that it is possible to test each brake set independently from outside of the well.
- This brake set can be used as braking element for an Ascending Car Overspeed Protection and as braking element for an Unintended Car Movement Protection according EN 81-20:2014.
- For Ascending Car Overspeed Protection the tripping speed of governor contact shall be according Art. 5.6.6 of EN 81-20:2014.
- Any controller shall take the lift out of service when a fault in the correct lifting and dropping of the brake parts occurs.
- The Shenyang Bluelight Drive document "The Block Braking System, Instruction manual" must be provided with every brake/machine, in order to make the correct installation and maintenance.
- The installer of the lift needs to define the final complete UCMP solution taking into account the key-parameters of the WYT-T machine with BLB, 2x2044 Nm as UCMP stopping means.

An additional calculation shall be done to check whether the deceleration and stopping distance of the car is within the limits as required by EN 81-20:2014.

- In case of no releveing and no pre-door opening condition, there is no need of any additional safety devices for unintended car movement protection, but only where this brake is mounted on a gearless machine. The controller of the lift must check the signal from the brake monitoring contacts. If a failure is detected, the lift must be put out of service. Its release or the reset of the lift shall require the intervention of a competent person.
- The air-gap around the disc brake shall be covered by a rubber band, to prevent dirt from entering.
- The brake must be interrupted at the DC side of the brake connection to ensure the specified delay times  $t_{10}$  and  $t_{90}$ .
- The components are according the descriptions of chapter 2 in this report.

## 6. Conclusions

Based upon the results of the EU-type examination and the Test reports of SISE, Liftinstituut B.V. issues an EU-type examination certificate.

The EU-type examination certificate is only valid for products which are in conformity with the same specifications as the type certified product. The certificate is issued based on the requirements that are valid at the date of issue. In case of changes of the product specifications, changes in the requirements or changes in the state of the art the certificate holder shall request Liftinstituut B.V. to reconsider the validity of the certificate.

## 7. CE marking and EU Declaration of conformity

Every safety component that is placed on the market in complete conformity with the examined type must be provided with a CE marking according to article 18 of the Lifts directive 2014/33/EU under consideration that conformity with eventually other applicable Directives is proven.

Also every safety component must be accompanied by an EU declaration of conformity according to annex II of the Directive in which the name, address and Notified Body identification number of Liftinstituut B.V. must be included as well as the number of the EU-type examination certificate.

An EU type-certified safety component shall be random checked e.g. according to annex IX of the Lifts directive 2014/33/EU before these safety components may be CE-marked and may be placed on the market. For further information see regulation 2.0.1 'Regulations for product certification' on [www.liftinstituut.com](http://www.liftinstituut.com).

Prepared by:

Certification decision by:



W.Visser  
Product Specialist Certification  
Liftinstituut B.V.

## Annexes

### Annex 1a : Outline drawing of BLB, 2x2044 Nm brake

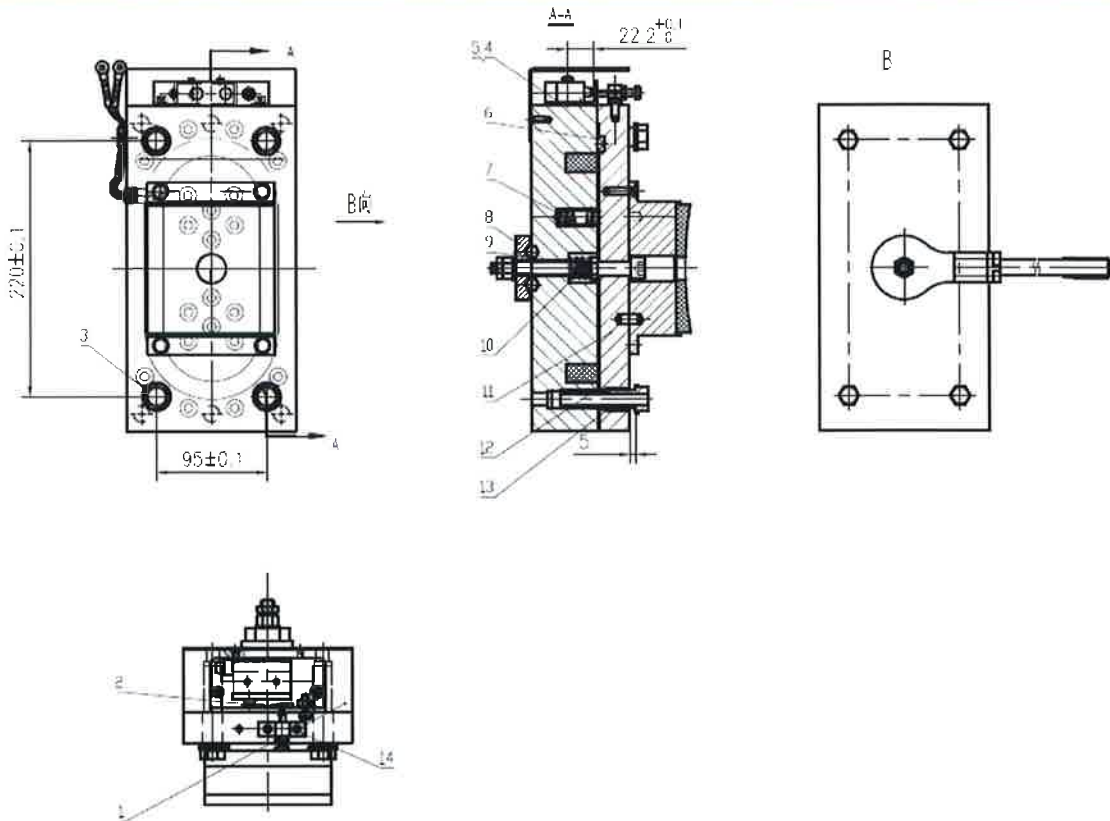



**Annex 1b: Test stand with BLB brake and WYT-T traction machine**

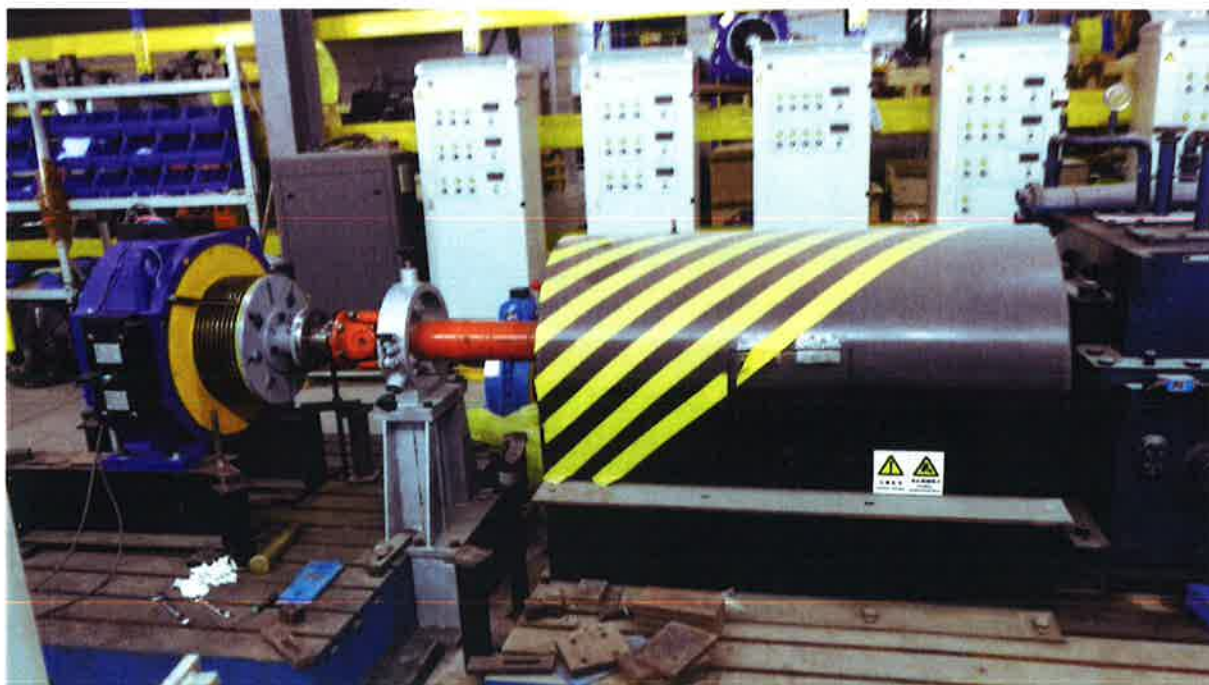

**Annex 2. : Documents of the Technical File which were subject of the examination**

title	document number	date
Drawings	WYT-TA3	23-08-2017
Drawings	WYT-TE3	23-08-2017
Drawings	WYT-U3	14-07-2017
Drawings	WYT-V4	23-08-2017
Brake Calculations	Ver.1	17-05-2018
Main axis calculation	Ver.1	25-08-2017
Instruction Manual	Version A1	03-2017
ACOP test reports:	2017AF0144	28-02-2017
UCMP test reports:	2017AF4186	01-12-2017

**Annex 3. Reviewed deviations from the standards**

EN xx-x par.	Requirement	Accepted design
x.x.x		

**Annex 4. Revision overview****REVISIONS OF THE CERTIFICATE AND REPORT**

<b>Rev.:</b>	<b>Date</b>	<b>Summary of revision</b>
-	02-08-2018	Original